

- 1? FUNCTION: OFF-ON
- 2? RATING: UL: 250VAC 1/2HP 8A 250VAC 1/4HP 10A 125VAC 1/4HP  
CQC: 6A/12A 250VAC  
ENEC VDE: 6(4)A 250VAC  $\mu$  T105
- 3? OPERATION FORCE: 650 $\pm$ 350gf
- 4? CONTACT RESISTANCE:  $\leq 50$  m $\Omega$
- 5? INSULATION RESISTANCE:  $\geq 100$  M $\Omega$
- 6? DIELECTRIC WITHSTAND: TERMINAL TO BUTTON 3000VAC/5mA/1MINUTE  
TERMINAL TO TERMINAL 1500VAC/5mA/1MINUTE
- 7. CIRCUIT DIAGRAM:

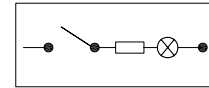

8. SUGGESTED PANEL HOLE SIZE:

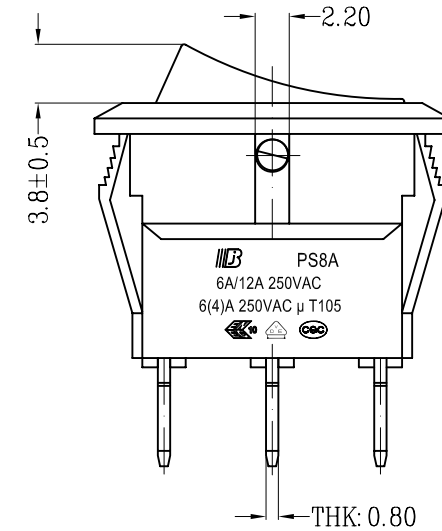
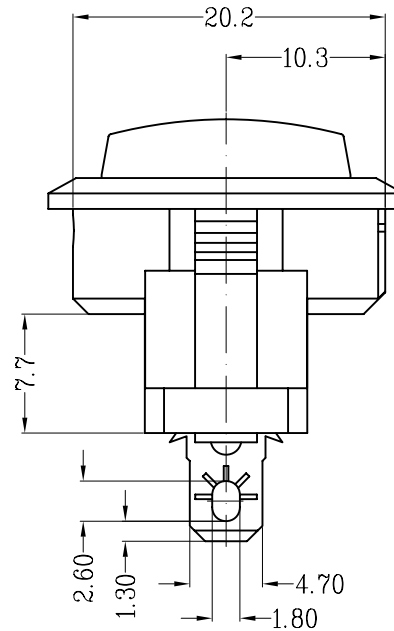
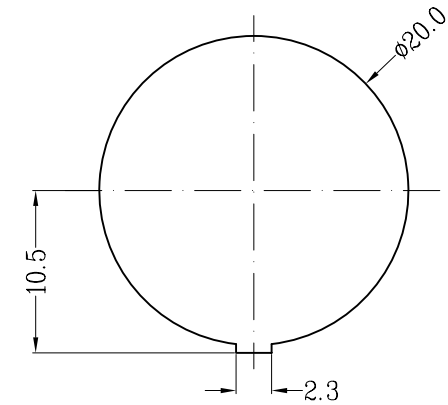

TOLERANCE UNLESS SPECIFIED				
X: $\pm 0.30$ XX: $\pm 0.15$ ANGULAR $\pm 3.0^\circ$				
PROJECTION		V1.0		
ISSUE	DATE	DESCRIPTIONS OF REVISION		APPD.
TITLE: ROCKER SWITCH		UNIT: mm	SCALE: NOT SCALE	DRWG NO.: BEJ-FH-W0719
MODEL: PS8A-7B-B1R3-2H15-02(A22269)		FUNCTION: OFF-ON		DWN. 黄荟荟 2017-02-17
		贝 尔 佳 电 子 有 限 公 司 BEI ER JIA ELECTRONICS CO.,LTD		CHK'D. 冯 辉 2017-02-17
				APPD. 谭云锋 2017-02-17



Product Specification (產品規格书)

Model No.(型號):  
PS8A-7B SeriesIssue Date(發佈日期):  
2016 年 07 月 15 日**1. General** [一般描述]

1.1 Part name [產品名稱]: PS8A-7B Series Rocker Switch [PS8A-7B 系列船形開關]

1.2 Function[功能]:

A	OFF-ON
B	ON-OFF-ON
C	ON-ON

1.3 Operating temperature: -10°C~105°C

[使用環境溫度]

1.4 Standard testing condition: Normal Temperature(25°C±10°C)、Normal humidity(45~85%RH)、

[測試條件]

Normal atmospheric pressure(860~1060hpa)

[溫度(25°C±10°C)、濕度(45~85%RH)、大氣壓力(860~1060hpa)]

1.5 Appearance [外觀]: See attached dwg. [見附件圖紙]

**2. Approval/Rating** [認證/規格]

Approval [安規]	Rating [規格]	Electrical Life [壽命]	Remarks [備註]
ENEC VDE	6(4)A 250VAC $\mu$ T105	1E4	Approved
CQC	6A/12A 250VAC	1E4	
UL	250VAC 1/2HP 8A 250VAC 1/4HP 10A 125VAC 1/4HP	6E3	

**3. Electrical Characteristics** [電氣特性]

No. [序號]	Item [項目]	Condition [條件]	Criteria [標準]
3.1	Electrical life [電氣壽命]	10,000 life cycles 6,000 life cycles [10,000 周次] [6,000 周次]	Switch perform 10 cycles of normal function after max. electrical life [開關達到最大電氣壽命後能繼續運行 10 周次]
3.2	Contact Resistance [接觸阻抗]	Initial : Test current:100mA [起始: 測試電流: 100mA]	$\leq 50m\Omega$
3.3	Contact gap [接觸間隙]	In off position [在 OFF 位]	$> 1.5mm$
3.4	Insulation resistance [絕緣阻抗]	Between terminals to case at 500 VDC for 5 seconds [腳與外殼間承受 500VDC, 保持 5 秒]	$\geq 100M\Omega$
3.5	Dielectric strength [耐壓強度]	Between terminals of contacts 1500VAC 5mA for 1 minute [腳與腳間承受 1500VAC, 5mA 保持 1 分鐘] Between terminals to button 3000VAC 5mA for 1 minute [腳與外殼間承受 3000VAC, 5mA 保持 1 分鐘]	Measurement before life test, no flash or dielectric breakdown [量度於壽命測試前, 無閃光或擊穿現象]



Product Specification (產品規格書)

Model No.(型號):  
PS8A-7B SeriesIssue Date(發佈日期):  
2016 年 07 月 15 日

## 4. Load Test [负载测试]

No.[序號]	Item [項目]	Condition [條件]	Criteria [標準]
4.1 IEC61058 测试 [IEC61058 Test]	Increase-voltage at accelerated speed: [升壓加速測試]	Testing voltage & current: Increase 1.15 times The number of operating cycles: 100 Power factor: 0.95±0.05(0.6+0.05/-0) Ambient temperature: 25±10°C Operating rate&speed: 1s ON, 3s OFF; 80mm/s [測試電壓和電流: 1.15 倍額定電壓; 操作迴圈次數: 100 次; 功率因數: 0.95±0.05(0.6+0.05/-0); 環境溫度: 25±10°C; 操作頻率和速度: 1 秒通, 3 秒斷; 80mm/s;	1、 The temperature rise test at the terminal carried out under rated current and ambient temperature of 25±10°C the temperature rise at the terminal dose not exceed 55K. 2、 Between terminals of terminals, Between terminals to button 1500VAC 5mA for 1 minute, Contact Resistance≤ 100mΩ 3、 The on-off function is Ok, no electrical problem, no mechanical breakdown, no abnormal appearance. 1、 通額定電流, 在周圍溫度為 25±10°C 的條件下進行溫升測試, 端子溫升不應超過 55K。 2、 介電強度在端子之間, 端子與外殼之間, 通過 1500VAC/min 高壓試驗; 漏電流設為 5mA; 接觸電阻≤100 mΩ 3、 通斷功能應正常, 無電氣或機械障, 外觀無異常。
	Slow speed test: [慢速測試]	Testing voltage & current: rated voltage & current The number of operating cycles: 100 Power factor: 0.95±0.05(0.6+0.05/-0) Ambient temperature: 25±10°C Operating rate&speed: 1s ON, 3s OFF; 20mm/s [測試電壓和電流: 額定電壓; 操作迴圈次數: 100 次; 功率因數: 0.95±0.05(0.6+0.05/-0); 環境溫度: 25±10°C; 操作頻率和速度: 1 秒通, 3 秒斷; 20mm/s;	
	Accelerated speed test: [加速測試]	Testing voltage & current: rated voltage & current The number of operating cycles: 9800 Power factor: 0.95±0.05(0.6+0.05/-0) Ambient temperature: 25±10°C Operating rate&speed: 1s ON, 3s OFF; 80mm/s [測試電壓和電流: 額定電壓; 操作迴圈次數: 9800 次; 功率因數: 0.95±0.05(0.6+0.05/-0); 環境溫度: 25±10°C; 操作頻率和速度: 1 秒通, 3 秒斷; 80mm/s;	
4.2 UL1054 测试 [UL1054 Test]	Overload Test: [过载測試]	Increase-current: Increase 150% The number of operating cycles: 50 Power factor: 1.0 Ambient temperature: 25±10°C Operating rate&speed: 6~10 cycles/min [測試電壓和電流: 150%倍額定電流; 操作迴圈次數: 50 次; 功率因數: 1.0; 環境溫度: 25±10°C; 操作頻率和速度: 6~10 次/分钟;	1、 Between terminals of terminals, Between terminals to button 1000VAC 5mA for 1 minute, Contact Resistance≤ 100mΩ 2、 The on-off function is Ok, no electrical problem, no mechanical breakdown, no abnormal appearance. 1、 介電強度在端子之間, 端子與外殼之間, 通過 1000VAC/min 高壓試驗; 漏電流設為 5mA; 接觸電阻≤100 mΩ 2、 通斷功能應正常, 無電氣或機械障, 外觀無異常。



Product Specification (產品規格書)

Model No.(型號):  
PS8A-7B SeriesIssue Date(發佈日期):  
2016 年 07 月 15 日

## 4. Load Test [负载测试]

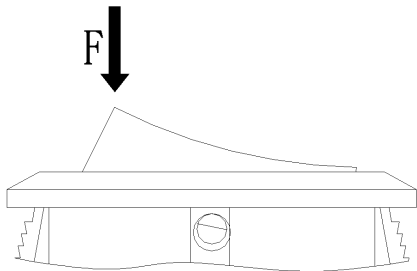
4.2 UL1054 测试 [UL1054 Test]	Endurance test: [耐久性测试]	Testing voltage & current: rated voltage & current The number of operating cycles: 6000 Power factor: 1.0 Ambient temperature: 25±10°C Operating rate&speed: 6~10 cycles/min [测试电压和电流: 额定电压和电流; 操作迴圈次數: 6000 次; 功率因數: 1.0; 環境溫度: 25±10°C; 操作頻率和速度: 6~10 次/分钟;	1、 The temperature rise test at the terminal carried out under rated current and ambient temperature of 25±10°C the temperature rise at the terminal dose not exceed 30°C. 2、 Between terminals of terminals, Between terminals to button 1000VAC 5mA for 1 minute, Contact Resistance≤ 100mΩ 3、 The on-off function is Ok, no electrical problem, no mechanical breakdown, no abnormal appearance. 1、 通額定電流, 在周圍溫度為 25±10°C 的條件下進行溫升測試, 端子溫升不應超過 30°C。 2、 介電強度在端子之間, 端子與外殼之間, 通過 1000VAC/min 高壓試驗; 漏電流設為 5mA; 接觸電阻≤100 mΩ 3、 通斷功能應正常, 無電氣或機械障, 外觀無異常。
No.[序號]	Item [項目]	Condition [條件]	Criteria [標準]
4.1	Mechanical life [機械壽命]	Perform 100,000 cycles operations [100,000 周次]	No detachable parts & switch w/ normal function [開關無損壞/功能正常]
4.2	Operating force [操作力]	Vertical force apply to the highest point of button [垂直力壓于按鈕最高點, 直至開關轉檔] 	650g•f±350g•f Notice Operating Force specification is only applied for standard knob. For other knob and lever types, please refer to specific drawing and/or specification. 注: 此操作力僅用適用於標準按鈕, 其他按鈕或控制桿請見成品圖和/或個別規格



## Product Specification (產品規格书)

Model No.(型號):  
PS8A-7B SeriesIssue Date(發佈日期):  
2016 年 07 月 15 日

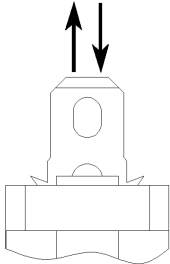
4.5	Terminal strength [端子強度]	Pulling & pushing force of max. 5kg apply to the terminal vertically [五金腳最大能承受垂直拔出/推入力5kg•f] 	No detach of terminal [腳無推入及脫離現象]
4.6	Solderability of terminals [端子可焊性]	Soldering temperature: 230±5°C [焊接溫度 230±5°C] Soldering time: 3±0.5 seconds [焊接時間 3±0.5 秒]	Solder should cover minimum 50% of soldering surface [焊接最少覆蓋 50%焊接表面]
4.7	Resistance to soldering heat [焊接阻熱性]	Soldering temperature: 260±5°C [焊接溫度 260±5°C] Soldering time: 5±0.5 seconds [焊接時間 5±0.5 秒]	No damage of plastic [塑膠無損壞]
4.8	Flammability rating [防火等級]	Thermoplastic UL 94V-2 [熱塑性塑膠 UL 94V-2]	\

5. Remarks: [備註]

Prepared by (制定):

黃芸芸

Checked by (審核):

馮輝

Approved by (核准):

譚云鋒

Date(日期): 2016-07-15

Date(日期): 2016-07-15

Date(日期): 2016-07-15