

Specification for Transducer	Page	3/9
	Revision No.	1.0
	Drawing No.	OEM4379R
Model No. : KPT-G1711A3-K4379		

1. 范围 Scope

This product specification is applied to the piezoelectric sounder in alarm systems. Please contact us when using this product for any other applications than described in the above.

本规格书适用于压电式蜂鸣器，通常它用在系统中做报警或提示的蜂鸣器用，如果将该产品用于其它领域，请与我们联系。

2. 概要 General

2.1 Out-Diameter : $\varnothing 16.8\text{mm}$

外径: $\varnothing 16.8\text{ mm}$

2.2 Height : 7mm

高度: 7 mm

2.3 Weight : 2 gr.

重量: 2克

2.4 Case Material/Color : PA/Black

壳体材质/颜色: PA/黑

3. 额定极限条件 Maximum Rating

	项目 Item	规格 Specification
3.1	最高输入电压 Maximum input Voltage	30Vp-p
3.2	工作温度范围 Operating Temperature Range	-20 ~ +80℃
3.3	储存温度范围 Storage Temperature Range	-30 ~ +100℃

Specification for Transducer Model No. : KPT-G1711A3-K4379	Page	4/9
	Revision No.	1.0
	Drawing No.	OEM4379R

4. 电性能 Electrical Characteristics

	项目 Item	规格 Specification
4.1	声压 Sound Pressure Level	80dB at 12Vp-p/4.0KHz/10cm
4.2	容量 Capacitance at 100Hz	14000pF ± 30%

测试条件参见下项

Refer to next item for measuring method.

5. 测试方法 Measuring Method

5.1 声压测试线路 S.P.L. Measuring Circuit

输入信号:12Vp-p,4.0KHz,方波

Input Signal:12Vp-p,4.0KHZ,Square wave

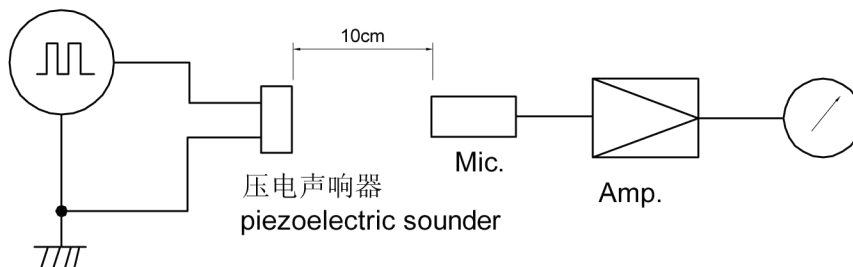

MIC : ND10 普通声级计或等同品

MIC : ND10 Sound Meter or equivalent

S.G. : DF1010 振荡器或等同品

S.G. : DF1010 Oscillater or equivalent

5.2 测试环境 Measuring Condition

温度+25±3℃, 湿度60±10%R.H.标准测试状态,在没有疑问的场合,可以在温度+5~+35℃,湿度45~85%R.H.的范围内测试.

Part shall be measured under a condition (Temperature :+5 to +35 °C, Humidity :45 to 85%R.H.) unless the standard condition (Temperature :+25 ±3°C, Humidity :60 ±10 %R.H.) is regulated measure.

Specification for Transducer Model No. : KPT-G1711A3-K4379	Page	5/9
	Revision No.	1.0
	Drawing No.	OEM4379R

6. 机械性能 Physical Characteristics

	实验项目 Item	实验条件 Test Condition	实验后规格 Specification
6.1	耐冲击性 Shock	<p>峰值加速度 490m/s^2, 半正弦波, XYZ 三个方向各3次冲击实验后, 测试声响器.</p> <p>Sounder shall be measured after being applied shock (490m/s^2) for each three mutually perpendicular directions to each of 3 times by half sine wave.</p>	<p>符合表1的要求</p> <p>The measured value shall meet Table 1.</p>
6.2	耐振动性 Vibration Resistant	<p>振动频率 10~55 Hz, 1.5mm 全振幅, XYZ 三个方向各2小时试验后, 测试声响器.</p> <p>Sounder shall be measured after being applied vibration of amplitude of 1.5mm with 10 to 55Hz band of vibration frequency to each of 3 perpendicular directions for 2 hours.</p>	
6.3	耐焊接性 Soldering Heat Resistance	<p>将声响器的插针插入(插至距声响器壳体 1.5mm 处为止) $+300 \pm 5^\circ\text{C}$ 的焊锡槽 3 ± 0.5 秒或 $+260 \pm 5^\circ\text{C}$ 的焊锡槽 10 ± 1 秒, 然后在常温中放置4小时后, 测试声响器.</p> <p>Lead terminal are immersed up to 1.5mm from sounder's body in solder bath of $+300 \pm 5^\circ\text{C}$ for 3 ± 0.5 seconds or $+260 \pm 5^\circ\text{C}$ for 10 ± 1 seconds, and then sounder shall be measured after being placed in natural condition for 4 hours.</p>	
6.4	可焊性 Solderability	<p>先将声响器的插针浸入松香液 5秒钟, 然后浸入 $+260 \pm 5^\circ\text{C}$ 熔融的锡槽中 3 ± 0.5 秒.</p> <p>Lead terminals are immersed in rosin for 5 seconds and then immersed in solder bath of $+260 \pm 5^\circ\text{C}$ for 3 ± 0.5 seconds.</p>	
6.5	插针强度 Terminal Strength Pulling	<p>分别在每个插针的轴向施加 9.8 牛顿的静荷重 10 秒.</p> <p>The force 10 seconds of 9.8N is applied to each terminal in axial direction.</p>	

Specification for Transducer Model No. : KPT-G1711A3-K4379	Page	6/9
	Revision No.	1.0
	Drawing No.	OEM4379R

7. 环境性能 Environmental Characteristics

	实验项目 Item	实验条件 Test Condition	实验后规格 Specification
7.1	高温放置 Dry Heat Test (Storage)	放置于温度 $+100 \pm 2^\circ\text{C}$ 的烘箱内96小时, 然后取出, 在常温下放置4小时后, 测试声响器。 After being placed in a chamber with $+100 \pm 2^\circ\text{C}$ for 240 hours and then being placed in natural condition for 4 hours, sounder shall be measured.	符合表1的要求 The measured value shall meet Table 1.
7.2	低温放置 Cold Test (Storage)	放置于温度 $-30 \pm 2^\circ\text{C}$ 的制冷箱内96小时, 然后取出, 在常温下放置4小时后, 测试声响器。 After being placed in a chamber with $-30 \pm 2^\circ\text{C}$ for 96 hours and then being placed in natural condition for 4 hours, sounder shall be measured.	
7.3	耐湿性 Humidity	放置于 90%~95% R.H., 温度 $+40 \pm 2^\circ\text{C}$ 的环境试验箱内96小时, 然后取出, 在常温下放置4小时后, 测试声响器。 After being placed in a chamber with 90 to 95%R.H. at $+40 \pm 2^\circ\text{C}$ for 96 hours and then being placed in natural condition for 4 hours, sounder shall be measured.	
7.4	温度循环 Temperature Cycle	先放置于温度 $-30 \pm 2^\circ\text{C}$ 的制冷箱内30分钟, 然后放置于室温($+20^\circ\text{C}$)15分钟后, 放置于 $+100 \pm 2^\circ\text{C}$ 的烘箱内30分钟, 再放置于室温($+20^\circ\text{C}$)15分钟。 经过以上循环5次, 在常温下放置4小时后, 测试声响器。 After being placed in a chamber at $-30 \pm 2^\circ\text{C}$ for 30 minutes, sounder shall be placed at room temperature($+20^\circ\text{C}$). After 15 minutes at this temperature, sounder shall be placed in a chamber at $+100 \pm 2^\circ\text{C}$. After 30 minutes at this temperature, sounder shall be returned to room temperature ($+20^\circ\text{C}$) for 15 minutes. After 5 above cycles, sounder shall be measured after being placed in natural condition for 4 hours.	

表 1 Table 1

项 目 Item	试验后变化量 Specification after test
声压级 Sound Pressure Level	初始值 $\pm 10\text{dB}$ Initial Value $\pm 10\text{dB}$

Specification for Transducer	Page	7/9
	Revision No.	1.0
Model No. : KPT-G1711A3-K4379	Drawing No.	OEM4379R

8. Dimensions

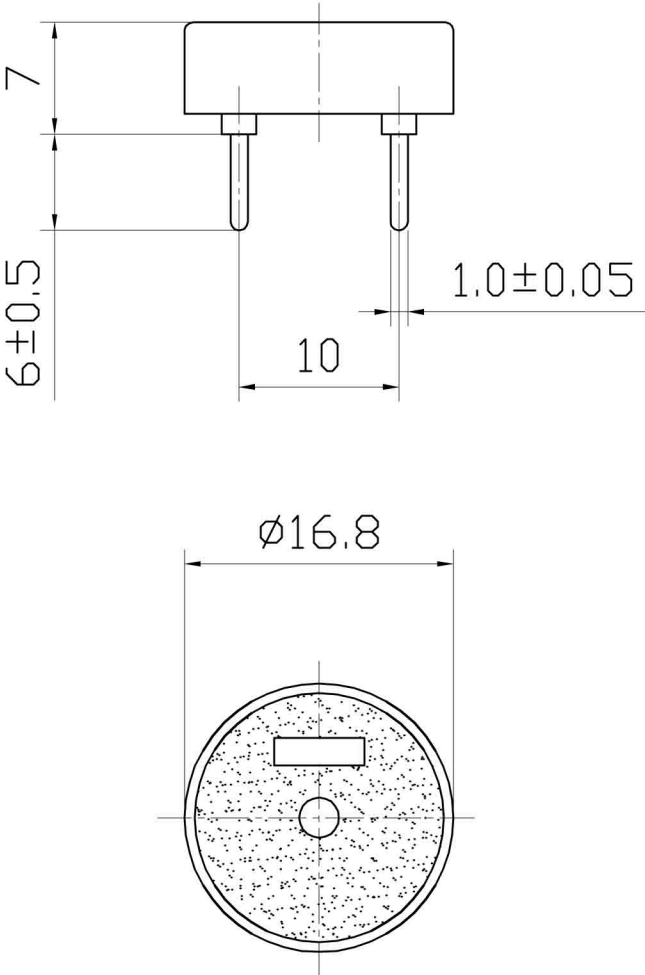

FIRST ANGLE PROJECTION

UNIT : mm
Tolerance : ±0.5