

REV.	DESCRIPTION	DRAWN	CHECKED	APPROVED
A	NEW RELEASE	LJH 04/09/06'	~	LJC 04/09/06'
B	增加规格	YCH 01/26/08'	~	LJC 04/09/06'
C	修改图纸错误	YCH 06/01/09'	~	

NOTES:

1. ELECTRICAL CHARACTERISTICS:

- 1.1 CONTACT RESISTANCE: 20mΩ Max.
- 1.2 DIELECTRIC WITHSTANDING VOLTAGE: 500V AC(rms) FOR 1 MINUTE.
- 1.3 INSULATION RESISTANCE: 1000MΩ Min.

2. ENVIRONMENT CHARACTERISTICS:

- 3.1 TEMPERATURE: -40°C~+105°C.

3. PRODUCT NUMBER CODE:

DS1023-03- X X X

CONTACT PLATING
 0: SELETIVE GOLD FLASH
 8: FULL GOLD FLASH
 2: NICKEL + GOLD FLASH

MOUNTIING TYPE
 V: V/T TYPE

No.OF CONTACTS
 1*2~1*40
 2*2~2*40

SERIES No.
 DS1023-03

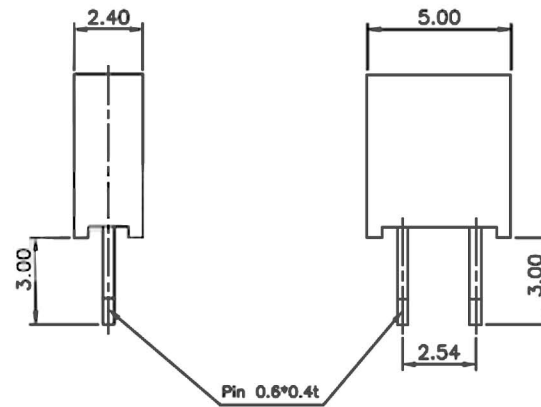
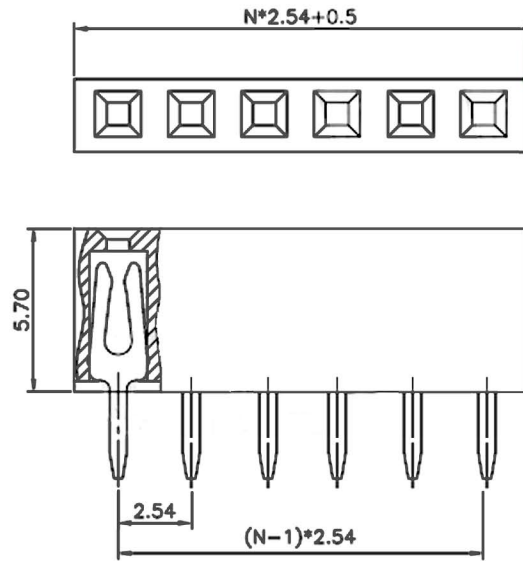

GENERAL TOLERANCE		ANGLE TOLERANCE		PROJECTION	TITLE	FEMALT HEADER PITCH	
X.	±0.60	X.	±5°	mm		2.54mm TYPE H=5.70mm	
.X	±0.38	.X	±3°	A4	SERIES	DS1023-03 SERIES	
.XX	±0.25	.XX	±2°				
DRAWING TYPE	CUSTOMER						
SCALE	1:1	SHEET	1 OF 1				
DRAWING NO.	C-DS1023-03-XXX-C						