

LED Panel Light



**Features**

- Elegant shaped.
- High efficiency, save more energy.
- Fast and easy install.
- Long life time, low maintenance cost.

**Application**

- Hotels
- Conference / Meeting rooms
- Factories & Offices
- Commercial Purposes
- Residential / Institution Buildings
- Schools, Colleges & Universities
- Other Lighting

**Specifications**

• Length	600*600mm/300*1200mm	• Material	AL+PC
• Power	40W	• Color Rendering Index	>80Ra, R9>0
• Correlated Color Temperature	4000K	• Certification requirements	CE,RoHS
• Protection class IEC	Class II	• Dimmable	NOT
• Input Voltage	100-240V	• Input Frequency	50/60Hz
• Ingress protection code	IP20	• Lamp life	30000/50000Hrs
• LED	HENSEL	• Operating humidity	10%~90%
• Lamps operating temperature	-20℃~+45℃	• Light storage temperature	-20℃~+60℃
• Installation	Ceiling/suspension install	• Warranty	3/5 years

Model	Power	CCT	lm/W	PF	CRI	View Angle	Driver	Warranty
PBD-C432A5-1	40W	4000K	85	>0.9	>80Ra	110°	CE driver	3 Yeas
PBD-C432A5-1	40W	4000K	120	>0.9	>80Ra	110°	TUV driver	5 Years
PBD-C432A6-2	40W	4000K	85	>0.9	>80Ra	110°	CE driver	3 Yeas
PBD-C432A6-2	40W	4000K	120	>0.9	>80Ra	110°	TUV driver	5 Years

## Dimensional drawing

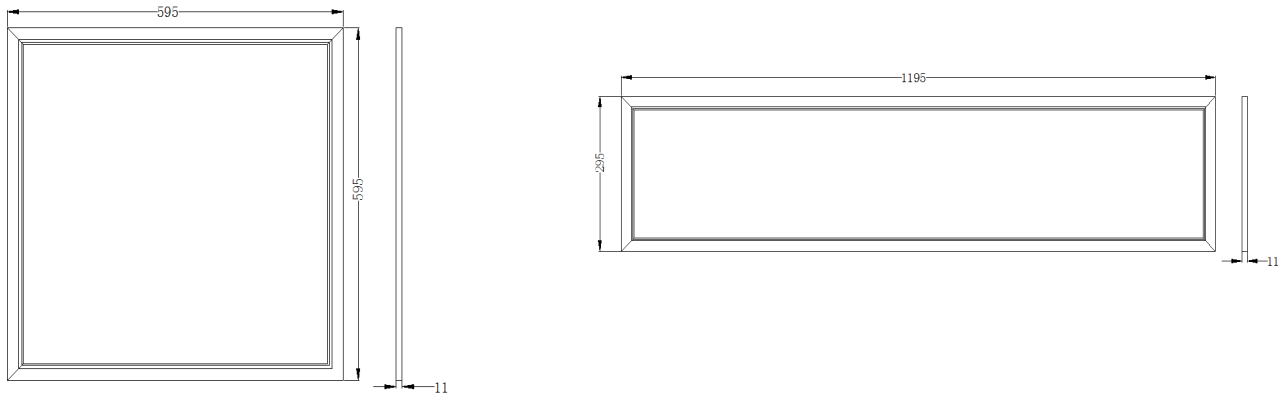

## Light Distribution

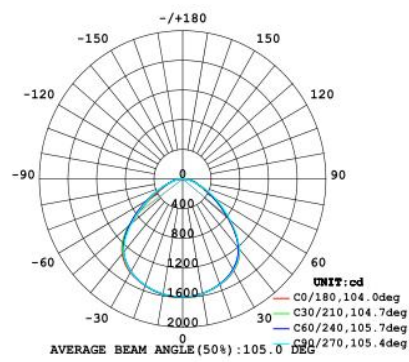

## Product details

