

# SPECIFICATION

## 1. DIMENSIONS (UNIT: mm)

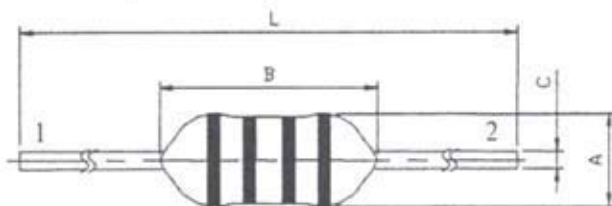

A	Ø3.2 Max.
B	7.0 Max.
C	Ø0.50±0.05 (0.1~18 $\mu$ H) Ø0.48±0.05 (22~1000 $\mu$ H)
L	61.0±1.0

COLOR RING 1 2 3 4

\* THE LENGTH OF THE TERMINAL PINS DOES NOT INCLUDE THE SOLDER TIP.

## 2. CIRCUIT



## 3. MARKING

COLOR	FIRST FIGURE	SECOND FIGURE	MULTIPLIER	TOLERANCE
	1	2		3
BLACK	0	0	1	± 20%
BROWN	1	1	10	-
RED	2	2	100	-
ORANGE	3	3	1000	-
YELLOW	4	4	-	-
GREEN	5	5	-	-
BLUE	6	6	-	-
VIOLET	7	7	-	-
GRAY	8	8	-	-
WHITE	9	9	-	-
GOLDEN	-	-	0.1	± 5%
SILVER	-	-	0.01	± 10%



## ELECTRICAL CHARACTERISTICS

No.	PART NO.	L ( $\mu$ H)	L TOLERANCE	Qu Min.	D.C.R. ( $\Omega$ ) Max.	RATED CURRENT Max. (mA)	S.R.F. (MHz) Min.	TESTING FREQUENCY (MHz)	MATERIAL
32	CEC-390□-812032NP	39	M, K, J	45	5.2	115	6.0	2.52	EM9D
33	CEC-470□-812033NP	47			5.8	110			
34	CEC-560□-812034NP	56			6.4	105			
35	CEC-680□-812035NP	68			7.2	100	5.5		
36	CEC-820□-812036NP	82			11	95	5.0		
37	CEC-101□-812037NP	100			12	90	4.5		
38	CEC-121□-812038NP	120			13	90	3.5	0.796	EL9H
39	CEC-151□-812039NP	150			16	85			
40	CEC-181□-812040NP	180			18	80	3.0		
41	CEC-221□-812041NP	220			20	75			
42	CEC-271□-812042NP	270			22	65	2.5		
43	CEC-331□-812043NP	330			22	60			
44	CEC-391□-812044NP	390			22	55	2.3		
45	CEC-471□-812045NP	470			24	55	2.2		
46	CEC-561□-812046NP	560			26	50	2.1		
47	CEC-681□-812047NP	680			28	45	1.8		
48	CEC-821□-812048NP	820			31	40	1.6		
49	CEC-102□-812049NP	1000			34	40	1.3		

\* □ : M:  $\pm 20\%$ , K:  $\pm 10\%$ , J:  $\pm 5\%$

### \* TESTING INSTRUMENTS

INDUCTANCE & Q: HP-4285A OR EQUIVALENT.

D.C.R.: HP-34420A OR EQUIVALENT.

RATED CURRENT: HP-4284A & HP-42841A, HP-E3632A & HP-34401A OR EQUIVALENT.

S.R.F. : HP-4395A, HP-4285A OR EQUIVALENT.

\* RATED CURRENT INDICATES THE VALUE OF CURRENT WHEN THE INDUCTANCE IS 90% OF ITS INITIAL VALUE AT D.C. SUPERPOSITION OR D.C. CURRENT WHEN THE COIL TEMPERATURE RISE BY  $20^{\circ}\text{C}$ , WHICHEVER IS THE LOWER.

## 5. GENERAL CHARACTERISTICS

### \* STANDARD TESTING CONDITIONS:

UNLESS OTHERWISE SPECIFIED, THE STANDARD RANGE OF ATMOSPHERIC CONDITIONS FOR MEASUREMENTS AND TESTS ARE AS FOLLOWS: AMBIENT TEMPERATURE: 15°C ~ 35°C. RELATIVE HUMIDITY : 25% ~ 85%. AIR PRESSURE : 86kPa ~ 106kPa.

IF THERE IS ANY DOUBT ABOUT THE RESULTS, MEASUREMENT SHALL BE MADE WITHIN THE FOLLOWING LIMITS: AMBIENT TEMPERATURE: 20°C ± 1°C. RELATIVE HUMIDITY : 63% ~ 67%. AIR PRESSURE : 86kPa ~ 106kPa.

No.	ITEMS		TEST CONDITIONS	SPECIFICATIONS
1	OPERATION TEMPERATURE			-25 ~ +85°C
	STORAGE TEMPERATURE			(INCLUDING COIL TEMPERATURE RISE) -40 ~ +85°C
2	LEAD TERMINAL STRENGTH	PULLING	A STATIC PULLING FORCE OF 25N IN A DIRECTION PARALLEL TO THE LEAD TERMINALS FOR 5±1 SECONDS.	NO TERMINAL BREAKAGE OR LOOSENING
		BENDING	LOAD WITH 3.0N AND 90° BENDING AND STRAIGHTENING TWICE IN TWO DIRECTIONS (UPWARD & DOWNWARD)	
3	DIELECTRIC WITHSTAND VOLTAGE TEST		APPLY D.C.500V BETWEEN WINDING AND BODY FOR 1 MINUTE.	NO DIELECTRIC DAMAGE
4	INSULATION RESISTANCE TEST		APPLY D.C.500V BETWEEN WINDING AND BODY FOR 1 MINUTE.	OVER 100 MΩ
5	OVER CURRENT TEST		INPUT 2 TIMES OF RATED INTO THE SAMPLE FOR 5 MINUTES.	NO FIRE OR ANY ABNORMALITY
6	RESISTANCE TO SOLDERING HEAT TEST		FIX THE SAMPLES ON A 1.6mm THICKNESS PCB, THEN DIP THE SAMPLE LEADS UP TO THE PCB INTO A SOLDERING BATH OF 260±5°C FOR 5±1 SECONDS.	NO MECHANICAL BREAKAGE. DEVIATION RELATIVE TO INITIAL VALUE: ΔL: WITHIN ±3.0% ΔQu: WITHIN ±20%
7	SOLDER ABILITY TEST		IMMERSE THE TERMINAL IN FLUX FOR 5 SECONDS. THEN DIP THE TERMINAL INTO A SOLDERING BATH OF 245±5°C FOR 2±0.5 SECONDS.	OVER 90% OF THE SURFACE BEING IMMERSED SHALL BE COVERED WITH NEW SOLDER UNIFORMLY.
8	VIBRATION TEST		AMPLITUDE: 1.5mm P-P FREQUENCY: 10 ~ 55 ~ 10Hz (1 MINUTE PER CYCLE) DURATION: 2 HOURS IN EACH OF X, Y, Z AXIS. (TOTAL 6 HOURS)	DEVIATION RELATIVE TO INITIAL VALUE: ΔL: WITHIN ±1.0% ΔQu: WITHIN ±20%
9	SHOCK TEST		PEAK ACCELERATION: 981m/s <sup>2</sup> DURATION OF PULSE: 10ms SHOCK TIMES: 3 TIMES IN EACH OF X, Y, Z AXIS. (TOTAL 9 TIMES)	DEVIATION RELATIVE TO INITIAL VALUE: ΔL: WITHIN ±1.0% ΔQu: WITHIN ±20%
10	HUMIDITY TEST		TEMPERATURE: 40°C ± 2°C HUMIDITY: 90% ~ 95%RH DURATION: 500 ± 12 HOURS.	DEVIATION RELATIVE TO INITIAL VALUE: ΔL: WITHIN ±10% ΔQu: WITHIN ±20%
11	DRY HEAT TEST		TEMPERATURE: 85°C ± 2°C DURATION: 500 ± 12 HOURS.	
12	COLD TEST		TEMPERATURE: -25°C ± 3°C DURATION: 500 ± 12 HOURS.	
13	DRY HEAT WITH LOAD		TEMPERATURE: 85°C ± 2°C LOAD CONDITION: RATED CURRENT DURATION: 500 ± 12 HOURS.	
14	DAMP HEAT WITH LOAD		TEMPERATURE: 40°C ± 2°C HUMIDITY: 90% ~ 95%RH LOAD CONDITION: RATED CURRENT DURATION: 500 ± 12 HOURS.	
15	THERMAL SHOCK		5 CONTINUOUS CYCLES SHOWN AS BELOW	
			TEMPERATURE	DURATION
			-25°C ± 3°C	30 MINUTES
		85°C ± 3°C	30 MINUTES	



## 6. CONSTRUCTION

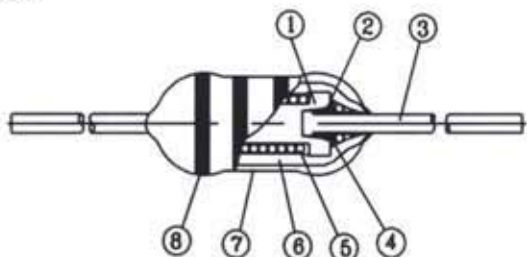

## MATERIAL LIST

No.	PARTS	MATERIAL	MANUFACTURER	COUNTRY OF ORIGIN	UL No.	FLAME CLASS	TEMP. CLASS
①	CORE	FERRITE CORE EM11, EM9D, EL9H OR EQUIVALENT	ZHONGSHAN COMPUTIMEHI FERRITE PRODUCTS CO., LTD.	CHINA	NA	NA	NA
②	ADHESIVE	EPOXY RESIN #6642-1 OR EQUIVALENT	GUANG ZHOU WELLS CHEMICAL CO., LTD.	CHINA	NA	NA	NA
③	PIN	TINNED COPPER WIRE OR EQUIVALENT	WELL FORE SPECIAL WIRE CORPORATION	CHINA	NA	NA	NA
④	SOLDER	Sn99.3-Cu0.7	ALPHA METALS LTD.	CHINA HONG KONG	NA	NA	NA
		OR Sn-Cu-Ni(SN100C4)	NIHON SUPERIOR CO., LTD.	JAPAN	NA	NA	NA
⑤	WIRE	POLYURETHANE ENAMELLED COPPER WIRE	PACIFIC-THAI ELECTRIC WIRE & CABLE CO., LTD.	THAILAND	E142108	NA	130°C
			JUNG SHING WIRE CO., LTD.	CHINA TAIWAN	E174837	NA	130°C
⑥	UNDER-COATING RESIN	BUTADIENE RESIN UV-321 OR EQUIVALENT	HOMETOWN INDUSTRIAL CO., LTD.	CHINA TAIWAN	NA	NA	NA
⑦	OVER-COATING RESIN	EPOXY RESIN I3012-G OR EQUIVALENT	HOMETOWN INDUSTRIAL CO., LTD.	CHINA TAIWAN	NA	NA	NA
⑧	COLOR CODE	MELAMINE RESIN OR EQUIVALENT	HOMETOWN INDUSTRIAL CO., LTD.	CHINA TAIWAN	NA	NA	NA

## 7. PACKING

\* PACKAGE TO BE ACCORDING TO PACKAGE SPECIFICATION (TICK THE RELEVANT "✓").

- KB-PAT003  
 KB-PAT004  
 SPECIAL FOR CUSTOMER KB \_\_\_\_\_

## 8. REMARK

\* THE WARNING FOR LEAD WIRE FORMING TO BE ACCORDING TO STD-003.

## 9. RoHS COMPLIANCE REMARKS:

\* LEAD WILL BE PRESENT IN THE FERRITE CORE OF THE FRIT MATRIX IN THE COMPONENT. THIS USE, IS EXEMPT FROM RoHS LEGISLATION PER THE ANNEX (ITEM 7), WHICH REFERS TO "LEAD IN ELECTRONIC CERAMIC PART".

# \* PACKAGE SPECIFICATION \*

APPLICABLE TYPE: CEC, TCEC

## 1. Taping Dimensions: (Unit : mm)

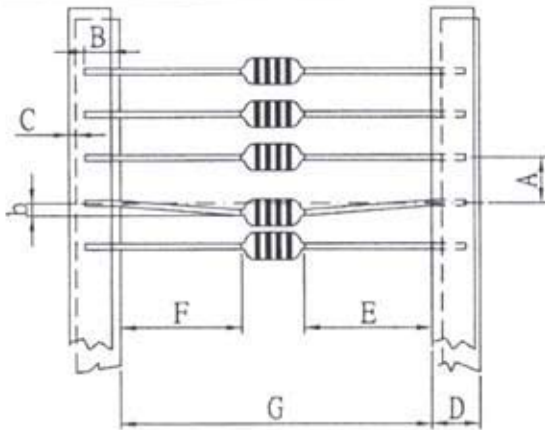

A : 5.0±0.5  
 B : 3.0MIN.  
 C : 0.8MAX.  
 D : 6±0.5  
 E-F: 1.0MAX.  
 G : 52<sup>+2.0</sup><sub>0</sub>  
 b : 1.2max.

## 2. Ammunition Packing

2,000 Pcs/Box

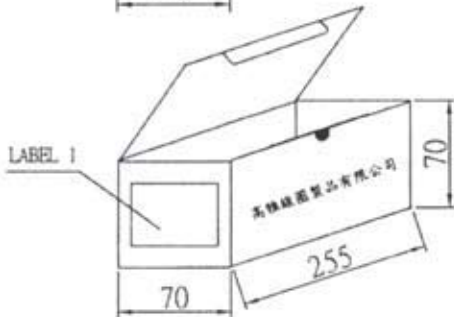
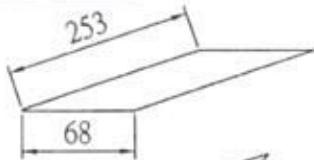

LABEL 1

Customer	
Lot No.	
Messrs.	
Part No.	
Qty.	

LABEL 2

\* UNLESS OTHERWISE STATED (IN COIL SPEC.) THE LABEL 2 SHALL BE ACCORDING TO CEC STANDARD SHOWN BELOW.

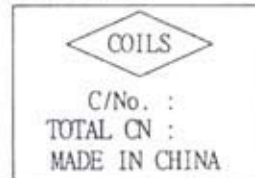

## 3. Carton

10 Boxes/Carton Total 20,000 Pcs

LABEL 2

LABEL 3

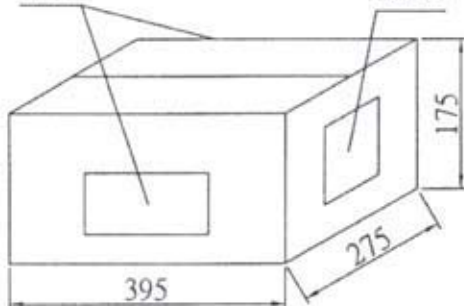

LABEL 3

LOT NO.	
COILS P/N:	
P/O#:	
Cust. P/N:	
QTY:	
DATE:	