

FEATURES:

- 15A switching capacity
- PC board mounting
- Size:19x15.5x20.2mm

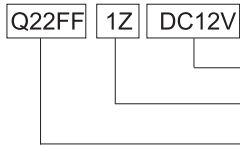

Q22FF



Coil Voltage 5,6,9,12,18,24,48VDC
 Contact Ratings 1H:1N/O 1Z:1C/O
 ZHNQI Type

CONTACT RATINGS

Contact Ratings	1H/1Z
Contact Resistance	100m Ω (1A 6VDC)
Contact Material	AgCdO, AgS _n O ₂
Contact capacity	15A 250VAC/30VDC

SPECIFICATION

Insulation Resistance	100M Ω .500VDC
Dielectric Strength	BCC 1500V 1 min
	BOC 750V 1 min
Operate Time	10ms/5ms
Terminal Type	PCB

COIL RATINGS

Nominal Coil Power	0.36W/0.45W
--------------------	-------------

COIL VERSIONS

Nominal Voltage VDC	Pull-in Voltage VDC	Release Voltage VDC	Coil Resistance Ω : ±10%
5	3.80	0.5	70
6	4.50	0.6	100
9	6.80	0.8	225
12	8.40	1.2	400
18	13.5	1.8	900
24	18.0	2.4	1600
48	36.0	4.8	4500



Q22FF

DIMENSION.BOTTOM VIEW

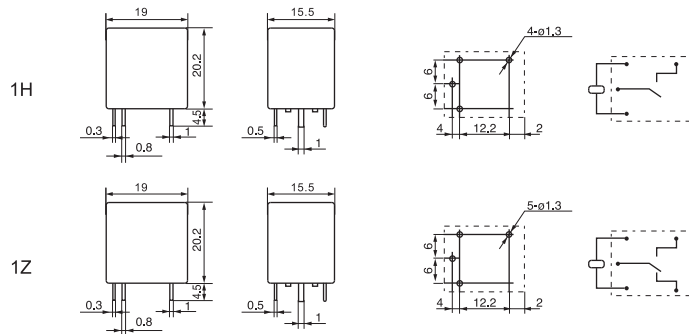

REFERENCE DATA

